

# FreeSpace 3

## subwoofer/satellite systems

### Product Overview

The Bose Professional FreeSpace 3 subwoofer/satellite systems are high-performance, extended-range loudspeaker systems designed for small to medium-sized installed applications requiring high fidelity and extended bandwidth reproduction of voice and music. Surface and flush components can be mixed and matched to provide greater flexibility to suit a wide range of applications. FreeSpace 3 systems feature a wide coverage pattern and frequency response down to 40 Hz.

### Key Features

**Subwoofer/satellite systems** that deliver high fidelity and extended bandwidth reproduction of voice and music for a wide range of installed applications, including retail, restaurant and hospitality operations

**Modular design** supports the flexibility for use of 2 or 4 satellites per Acoustimass bass module, and parallel connection of bass modules

**Mix and match** surface-mount and flush-mount components to work with different room decors and layouts for a variety of applications

**Flush-mount** components are plenum-rated when used with the optional plenum cover

**Selectable 70/100V** or low impedance with transformer tap adjustment on Acoustimass bass module

**Can be configured** for stereo or mono operation



### Applications

Retail stores

Restaurants and bars

Lobbies and conference rooms

Hospitality venues

## TECHNICAL DATA

# FreeSpace 3

## subwoofer/satellite systems

### Technical Specifications

SYSTEM PERFORMANCE				
	System		Satellite	Subwoofer
Frequency Response ( $\pm 3$ dB) <sup>1</sup>	50 Hz – 16 kHz		210 Hz – 16 kHz	50 Hz – 230 Hz
Frequency Range (-10 dB) <sup>1</sup>	40 Hz – 20 kHz		170 Hz – 20 kHz	40 Hz – 315 Hz
Nominal Dispersion	See components		170° conical	Omnidirectional below 200 Hz
Recommended High-Pass Filter	40 Hz high-pass filter		N/A	40 Hz high-pass filter
Loudspeaker EQ	Recommended		Recommended	Recommended
Overload Protection	PTC		N/A	PTC
Long-term Power Handling <sup>2</sup>	70/100V: 200 W (800 W peak) Low impedance: 100 W (400 W peak)		12 W (48 W peak)	70/100V, mono: 200 W (800 W peak) Low impedance, stereo: 50 W (200 W peak) per channel Low impedance, mono: 100 W (400 W peak)
Sensitivity (SPL / 1 W @ 1 m) <sup>3</sup>	82 dB-SPL		84 dB-SPL	Stereo, per channel: 76 dB-SPL Mono: 79 dB-SPL
Maximum SPL @ 1 m <sup>4</sup>	93 dB (99 dB-SPL peak in a 45,000 ft <sup>3</sup> room with RT60 of 1 s, $\pm 3$ dB)		Pink noise: 95 dB-SPL (101 dB-SPL peak) IEC noise: 92 dB-SPL (108 dB-SPL peak)	Stereo, per channel: 96 dB-SPL (102 dB-SPL peak) Mono: 102 dB-SPL (108 dB-SPL peak)
Nominal Impedance	4-satellite system: 6 $\Omega$ per channel 2-satellite system: 5 $\Omega$ per channel (surface-mount); 6 $\Omega$ per channel (flush-mount)		6 $\Omega$	Surface-mount: 5 $\Omega$ mono direct Flush-mount: 6 $\Omega$ mono direct (transformer bypassed)
Transformer Taps (70/100 V)	25 W, 50 W, 100 W, 200 W		N/A	25 W, 50 W, 100 W, 200 W
TRANSDUCERS				
	Satellite		Subwoofer	
Driver Complement	2.5 in (64 mm) full-range driver per satellite		5.25 in (133 mm) dual voice coil low-frequency driver	
PHYSICAL				
	Satellite		Subwoofer	
	Surface-mount	Flush-mount	Surface-mount	Flush-mount
Enclosure	High-impact polystyrene, textured	PC/ABS	High-density wood composite with solid color PVC laminate	PC/ABS
Grille	Cloth	Expanded metal	N/A	Expanded metal
Environmental	Indoor use only	Indoor use only	Indoor use only	Indoor use only

For additional specifications and application information, please visit [BoseProfessional.com](https://www.boseprofessional.com). Specifications subject to change without notice. 05/2024

## TECHNICAL DATA

# FreeSpace 3

## subwoofer/satellite systems

### Technical Specifications (continued)

<b>PHYSICAL</b> (continued)				
	<b>Satellite</b>		<b>Subwoofer</b>	
	<b>Surface-mount</b>	<b>Flush-mount</b>	<b>Surface-mount</b>	<b>Flush-mount</b>
Connectors	2-position screw-type barrier	2-position terminal block	Screw terminal	Multi-position screw-type barriers
Suspension/ Mounting	Wall-mount brackets, included Bracket angles: ±30° pitch, ±90° yaw	Integral quick-install mounting features Tab for seismic chain or safety cable	Wall-mount bracket, included (attached to module)	Integral quick-install mounting features 3 points at rear of housing for pendant mounting
Maximum Ceiling Thickness	N/A	38 mm (1.5 in)	N/A	48 mm (1.8 in)
Dimensions	Height × width: 77 × 77 mm (3.0 × 3.0 in) Depth with bracket: 149 mm (5.9 in) Depth without bracket: 102 mm (4.0 in)	Ø, outer flange: 157 mm (6.2 in) Depth: 123 mm (4.8 in) Ø, ceiling hole: 127 mm (5.0 in)	Height × depth: 356 × 345 mm (14.0 × 13.6 in) Width with bracket: 222 mm (8.8 in) Width without bracket: 191 mm (7.5 in)	Ø, outer flange: 391 mm (15.4 in) Depth: 189 mm (7.4 in) Ø, ceiling hole: 362 mm (14.3 in)
Net Weight	0.8 kg (1.8 lb)	0.9 kg (1.9 lb)	7.9 kg (17.5 lb)	6.4 kg (14.0 lb)
Shipping Weight	1.8 kg (4.0 lb)	2.3 kg (5.0 lb)	11.3 kg (25.0 lb)	9.1 kg (20.0 lb)
<b>PRODUCT CODES</b>				
	<b>Satellite</b>		<b>Subwoofer</b>	
	<b>Surface-mount</b> (pair)	<b>Flush-mount</b> (pair)	<b>Surface-mount</b>	<b>Flush-mount</b>
Black	040144	843091-0110	040146	843090-0110
White	040143	843091-0210	040145	843090-0210

#### Footnotes

1. Frequency response and range measured on-axis with recommended active EQ in an anechoic environment.
2. Power handling tested using pink noise filtered to meet IEC 268-5, 6-dB crest factor, 100 hours, with recommended EQ.
3. Sensitivity measured in free field (no boundary-loading gain) with recommended active EQ, referenced to 1 W / 1 m.
4. Maximum SPL calculated from sensitivity and power handling specifications, exclusive of power compression.

# FreeSpace 3

subwoofer/satellite systems

## Impedance

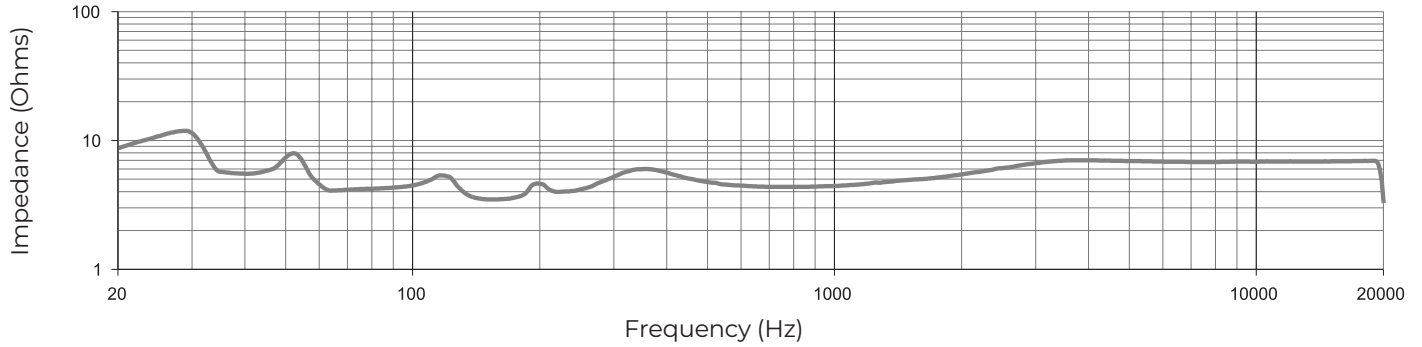

## On-axis Response

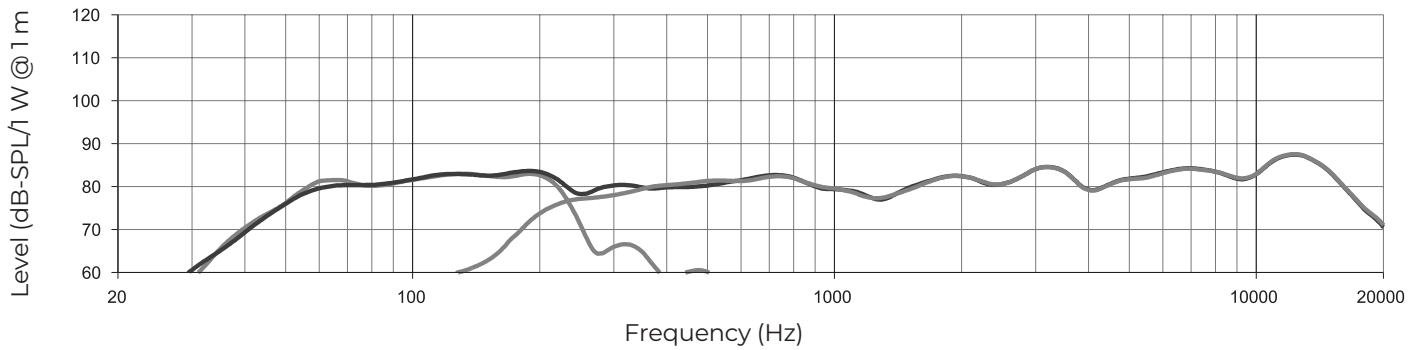

## Tap Chart

Tap setting	Mounting height				
	2.4 m (8.0 ft)	3.0 m (10.0 ft)	3.6 m (12.0 ft)	4.2 m (14.0 ft)	4.8 m (16.0 ft)
25W	87 dB-SPL	86 dB-SPL	86 dB-SPL	85 dB-SPL	84 dB-SPL
50W	90 dB-SPL	89 dB-SPL	89 dB-SPL	88 dB-SPL	87 dB-SPL
100W	93 dB-SPL	92 dB-SPL	92 dB-SPL	91 dB-SPL	90 dB-SPL
200W	96 dB-SPL	95 dB-SPL	95 dB-SPL	94 dB-SPL	93 dB-SPL

# FreeSpace 3

subwoofer/satellite systems

## Dimensions<sup>5</sup>

### Surface-mount Subwoofer

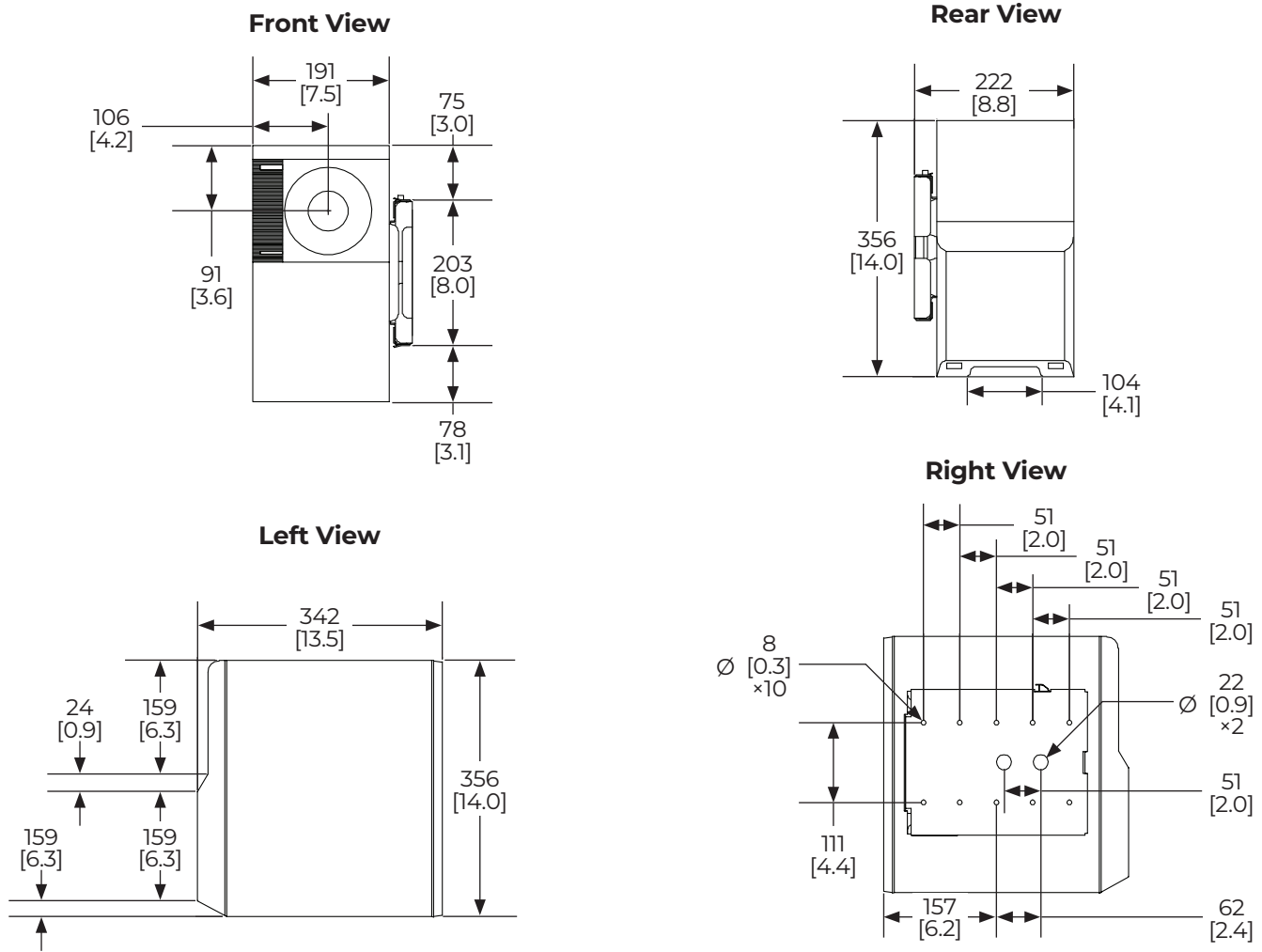

### Surface-mount Satellite

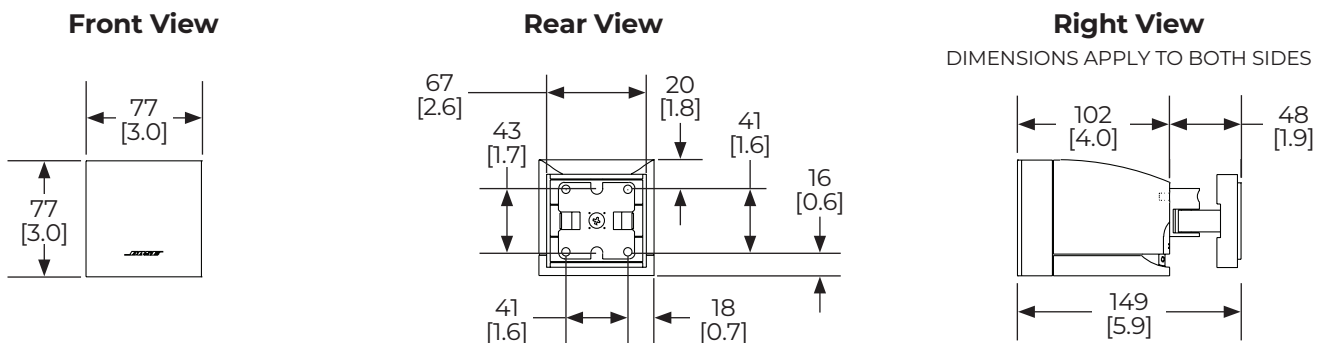

5. Dimensions are shown in millimeters over inches.

For additional specifications and application information, please visit [BoseProfessional.com](http://BoseProfessional.com). Specifications subject to change without notice. 05/2024

# FreeSpace 3

## subwoofer/satellite systems

### Dimensions (continued)

#### Flush-mount Subwoofer

Front View

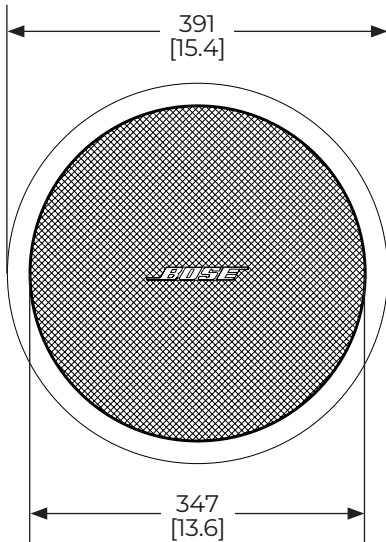

Rear View

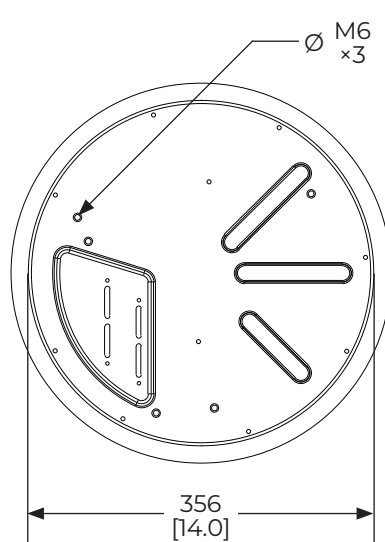

Right View

DIMENSIONS APPLY TO BOTH SIDES

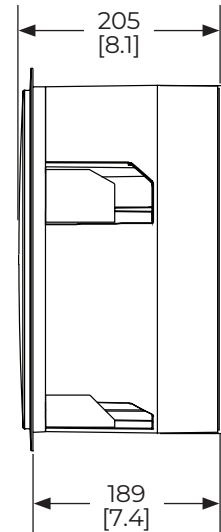

#### Flush-mount Satellite

Front View

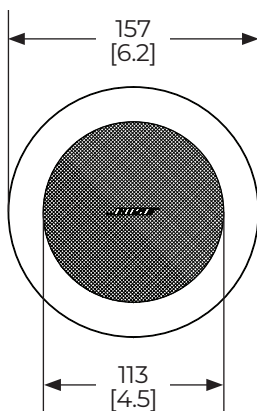

Rear View

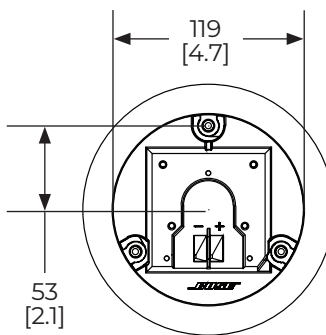

Bottom View

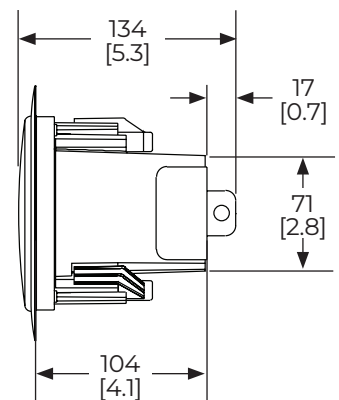

# FreeSpace 3

subwoofer/satellite systems

## Horizontal Plots, Surface-mount Satellite

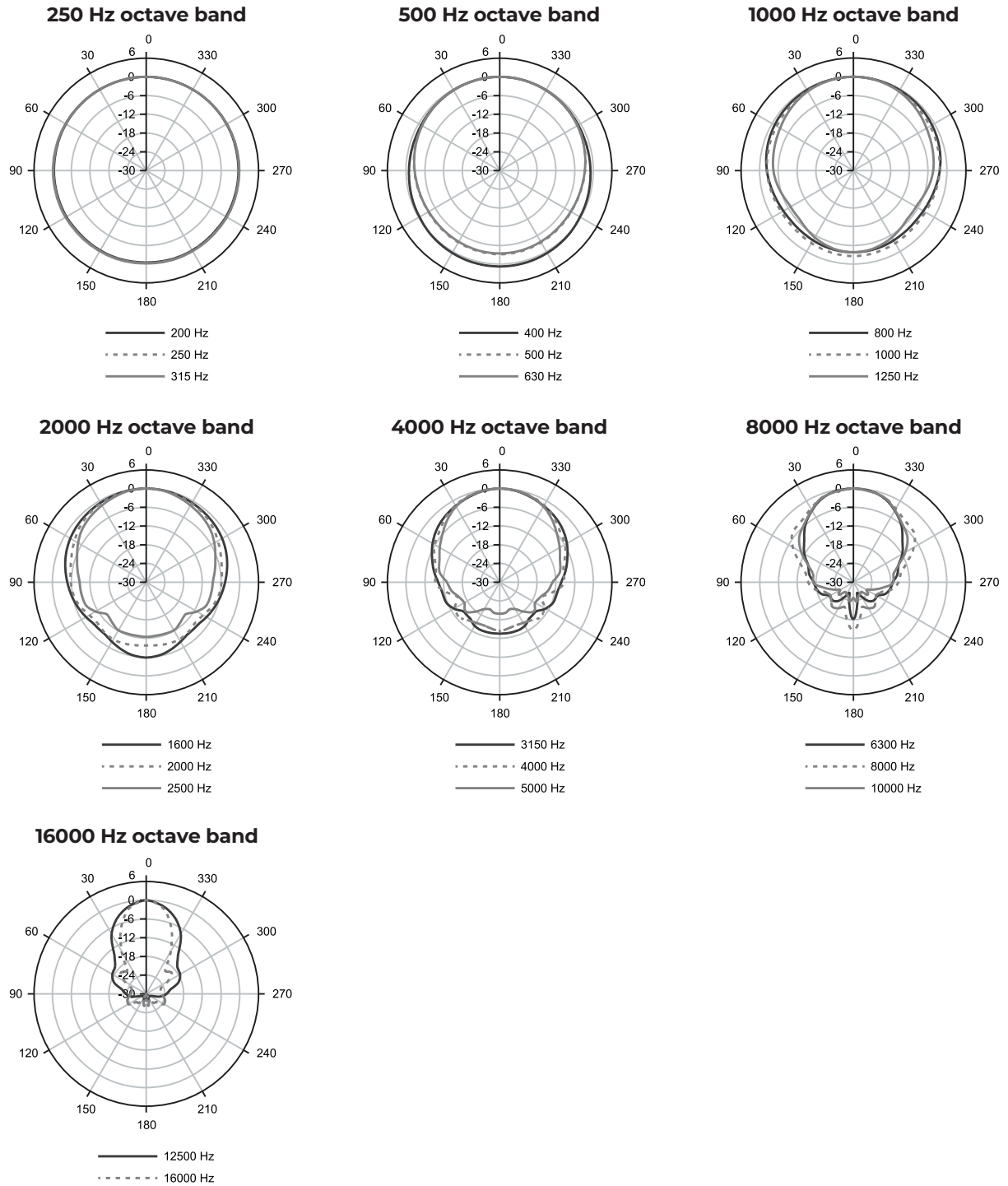

# FreeSpace 3

subwoofer/satellite systems

## Vertical Plots, Surface-mount Satellite

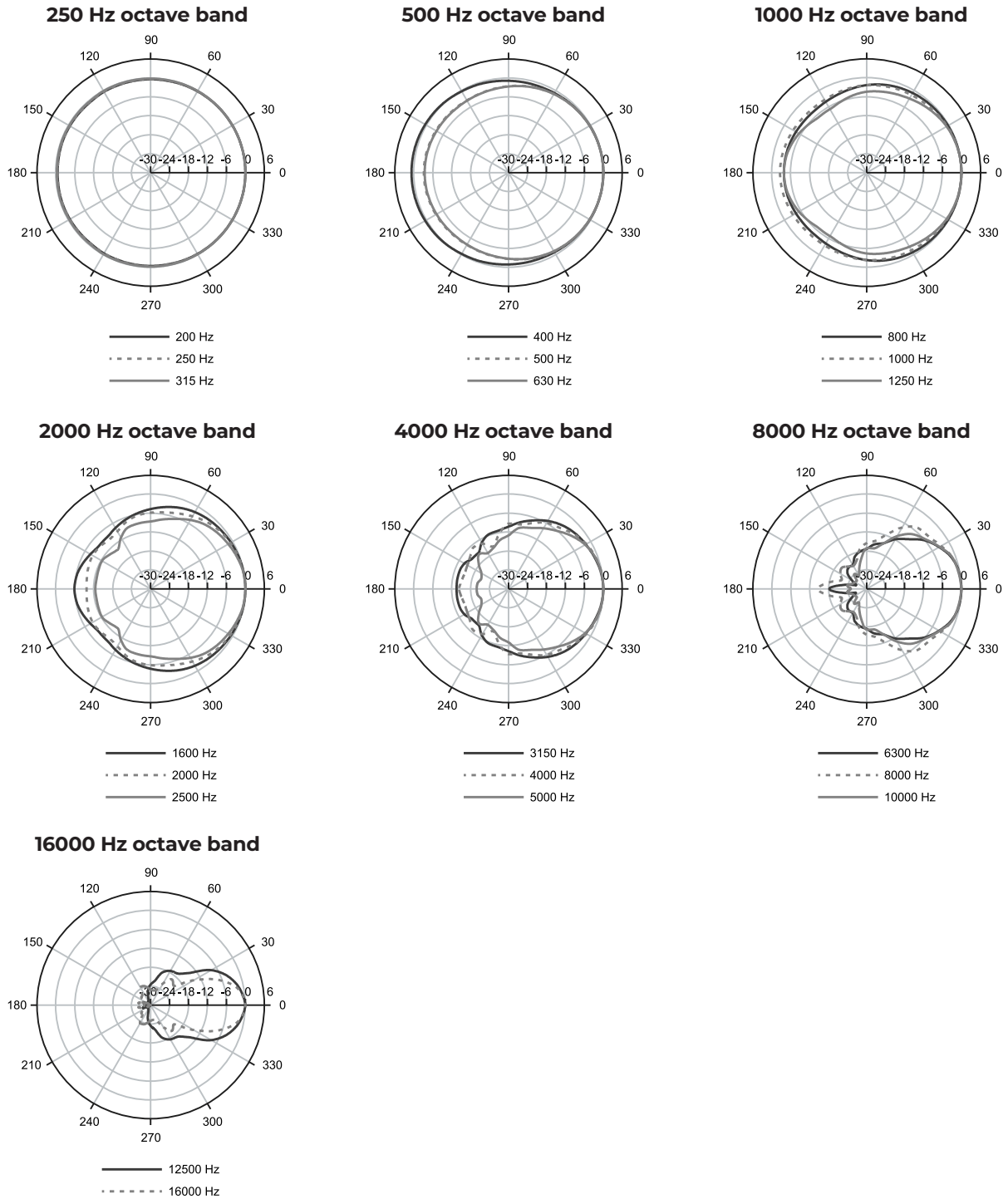



# FreeSpace 3

subwoofer/satellite systems

## Horizontal Plots, Flush-mount Satellite

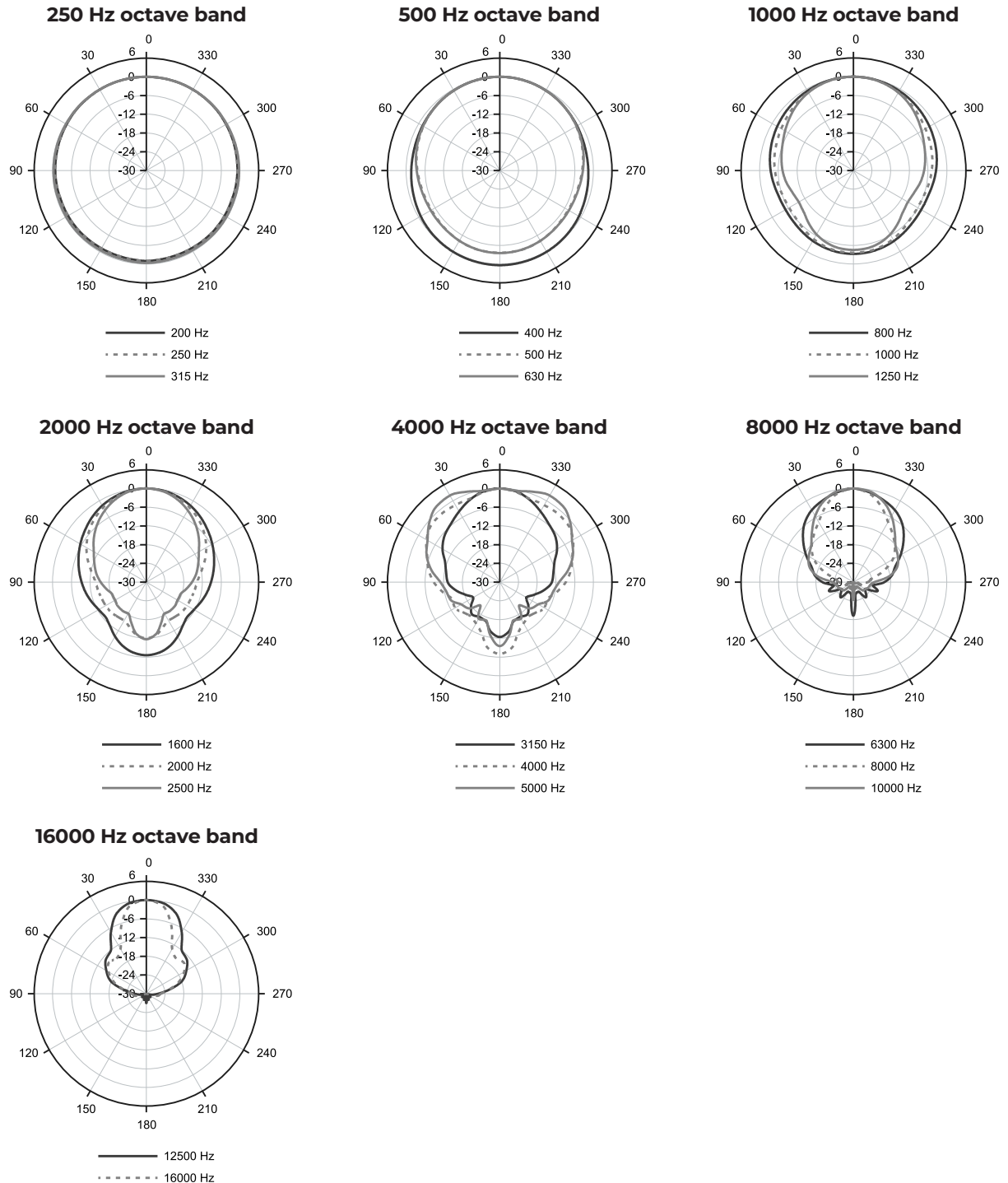

For additional specifications and application information, please visit [BoseProfessional.com](http://BoseProfessional.com). Specifications subject to change without notice. 05/2024

# FreeSpace 3

subwoofer/satellite systems

## Vertical Plots, Flush-mount Satellite

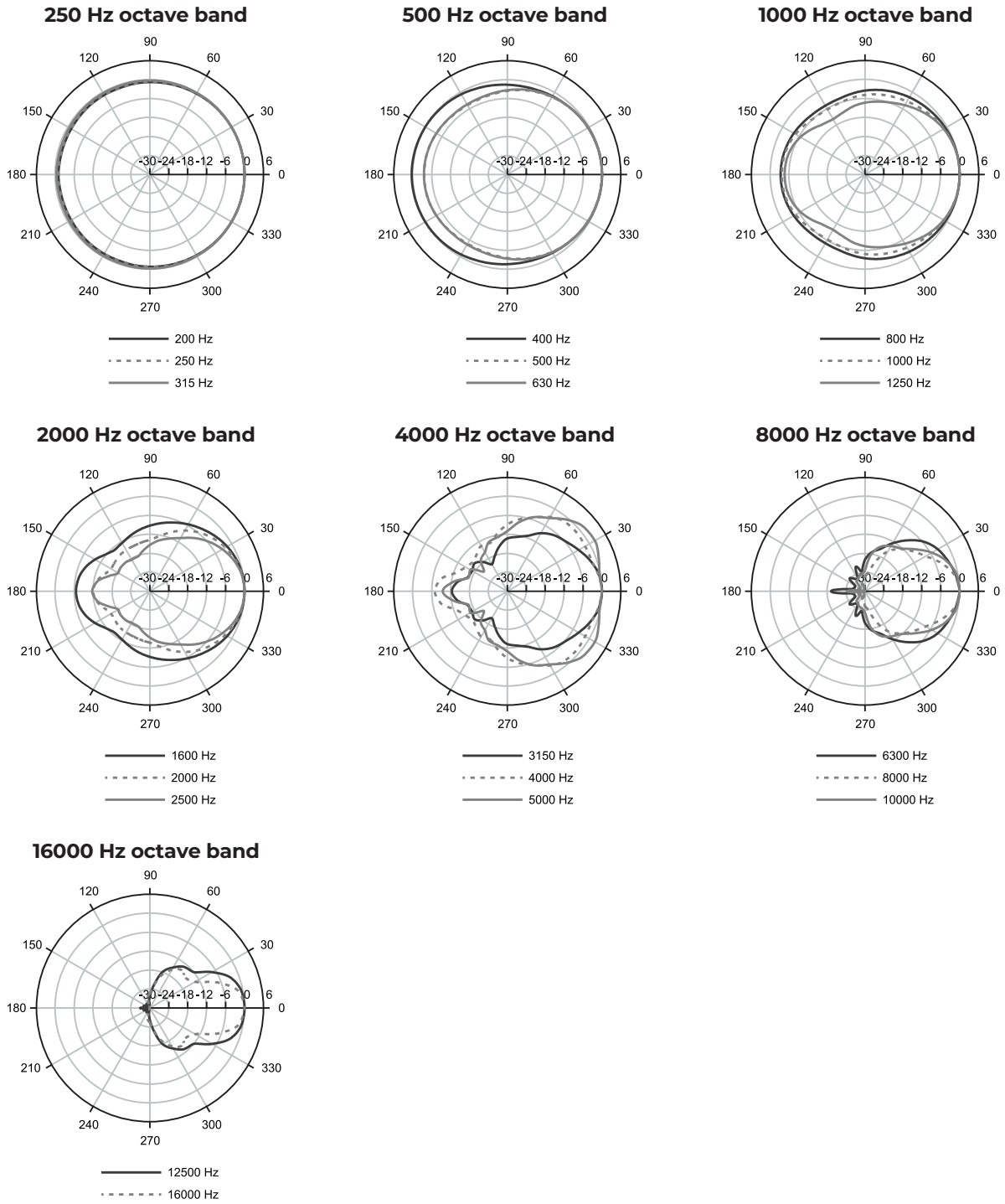

# FreeSpace 3

## subwoofer/satellite systems

### Architects' & Engineers' Specifications

The loudspeaker system shall be a 200 watt ported loudspeaker system that includes one Acoustimass bass module and two or four satellite loudspeakers. It shall be capable of producing 93 dB-SPL average in a 45,000 ft<sup>3</sup> room with an RT60 of 1 second in a range of 50 Hz to 16 kHz ( $\pm 3$  dB).

The module shall have one 5.25 in (133 mm) dual voice coil low-frequency driver. The module shall have an input impedance of 6 ohms (5 ohms for surface-mount module) for direct connection to unequalized low-impedance amplifier sources. The system shall be configured for use with either a 70/100V input or a low-impedance input. The transformer shall offer multiple taps of 25 W, 50 W, 100 W, and 200 W.

Each satellite loudspeaker shall have one 2.5 in (64 mm) full-range driver. The nominal average dispersion shall be 170° at -6 dB.

The input connectors shall consist of multi-position screw-type barriers on the flush-mount Acoustimass bass module, a spring-type barrier connector for the 70/100V inputs and a screw-type barrier strip for direct 4-8 ohm input on the surface-mount Acoustimass bass module, a two-position guillotine connector on the flush-mount satellite, and a two-position screw-type barrier on the surface-mount satellite. Wire jumpers for transformer settings shall be provided. Removable covers shall shield all bass module input and jumper connections.

The flush-mount bass Acoustimass module shall have dimensions of 15.4 in (391 mm) outer flange diameter; 14.25 in (361 mm) ceiling hole diameter; and 7.5 in (190 mm) height to top of housing. It shall weigh 14.0 lb (6.36 kg). The surface-mount Acoustimass bass module shall have dimensions of 14.0 in height  $\times$  8.7 in width (with bracket)  $\times$  13.6 in depth (356 mm  $\times$  221 mm  $\times$  345 mm) and shall weigh 17.5 lb (7.9 kg) with attached mounting bracket. Each flush-mount satellite loudspeaker shall measure 6.2 in (157 mm) outer flange diameter; 5.0 in (127 mm) ceiling hole diameter; and 5.0 in (127 mm) to top of housing. It shall weigh 1.9 lb (0.9 kg). Each surface-mount satellite loudspeaker shall measure 3.0 in height  $\times$  3.0 in width  $\times$  4.0 in depth (77 mm  $\times$  77 mm  $\times$  102 mm) and shall weigh 1.75 lb (0.8 kg).

The flush-mount Acoustimass bass module and flush-mount satellite enclosures shall be composed of PC/ABS with an expanded metal grille and shall meet plenum ratings when used with a plenum cover. The surface-mount Acoustimass bass module enclosure shall be composed of high-density wood composite with solid-color PVC laminate, black or white. The surface-mount satellite shall have a cloth grille and black or white polymer finish.

The loudspeaker shall be the FreeSpace 3 loudspeaker system.